

常熟市飞龙无纺机械有限公司

地址：中国·苏州常熟市支塘任阳
电话：+86-512-52581505/52587117
传真：+86-512-52583888/52587111
网址：www.feilong.cn
邮箱：info@feilong.cn

Changshu Feilong Nonwoven Machinery Co., Ltd.

Add: Renyang, Zhitang, Changshu City, Suzhou, China
Tel: +86-512-52581505/52587117
Fax: +86-512-52583888/52587111
Http: www.feilong.cn
E-mail: info@feilong.cn

FEILONG 飛龍®

本样本所有内容，包括但不限于各种版式、图案、标识、技术参数以及文字资料的全部或者部分，其知识产权和解释权均完全属于常熟市飞龙无纺机械有限公司所有。

All data in this sample, including but not limited to all or part of various formats, patterns, logos, technical parameters, and textual materials, its intellectual property and interpretation rights are fully owned by Changshu Feilong Nonwoven Machinery Co., Ltd.

来源于大自然的享受
A gift of nature

可降解、可冲散
DEGRADABLE AND FLUSHABLE

湿法水刺生产线 整厂方案
WETLAID SPUNLACE PRODUCTION LINE
COMPLETE PLANT SOLUTION

——走向绿色的飞龙技术
Feilong technology moving towards green



FEILONG 飛龍®

中国·苏州 SUZHOU CHINA



科技造福大众
TECHNOLOGY WILL BENEFIT THE PUBLIC

飞龙研发制造工厂
R&D and manufacturing factory of Feilong

植物纤维

环保、舒适无纺布用途广泛
未来发展方向

Plant fiber

Environmentally friendly and comfortable non-woven fabrics have a wide range of application
Future development direction

飞龙技术团队

40年的坚持
湿法水刺生产线
全球内服务技术一流

Technical team of Feilong

We have 40 years of persistence
Wetlaid spunlace production line
Global first-class service technology



宠物湿巾 Pet wipes



卸妆湿巾 Makeup remover wipes



婴儿湿巾 Baby wipes



飞龙技术团队 Technical team of Feilong



飞龙生产线 Production line of Feilong

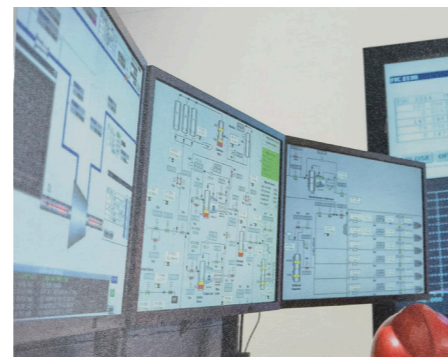

智能化管理 Intelligent management



湿厕纸 Toilet flushable wipes



老人护理 Elderly care wipes



各种湿巾与干巾 Various wet and dry wipes

可冲散可降解湿法水刺生产线
Flushable and degradable
Wetlaid spunlace production line



主要技术参数/Main technical parameters

适合原料 Applicable raw materials	木浆/短切粘胶等 Wood pulp/short cut viscose
产品克重 Product GSM	40-90g/m ²
设备宽度 Machine width	2.5m 3.6m
生产速度 Production speed	120m/min 180m/min

图片版权归飞龙所有，侵权必究
The copyright of the image belongs to Feilong, all rights reserved

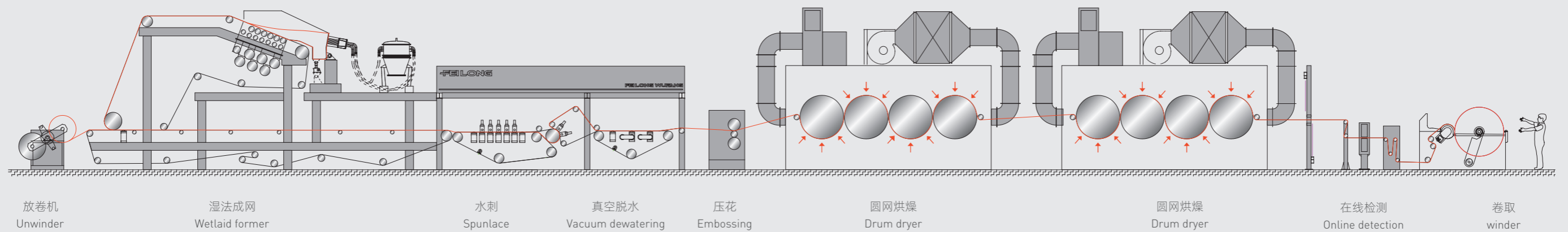

可降解、可冲散、复合纤维
湿法水刺生产线
 Degradable, flushable,
 composite fibers
 Wetlaid spunlace production line

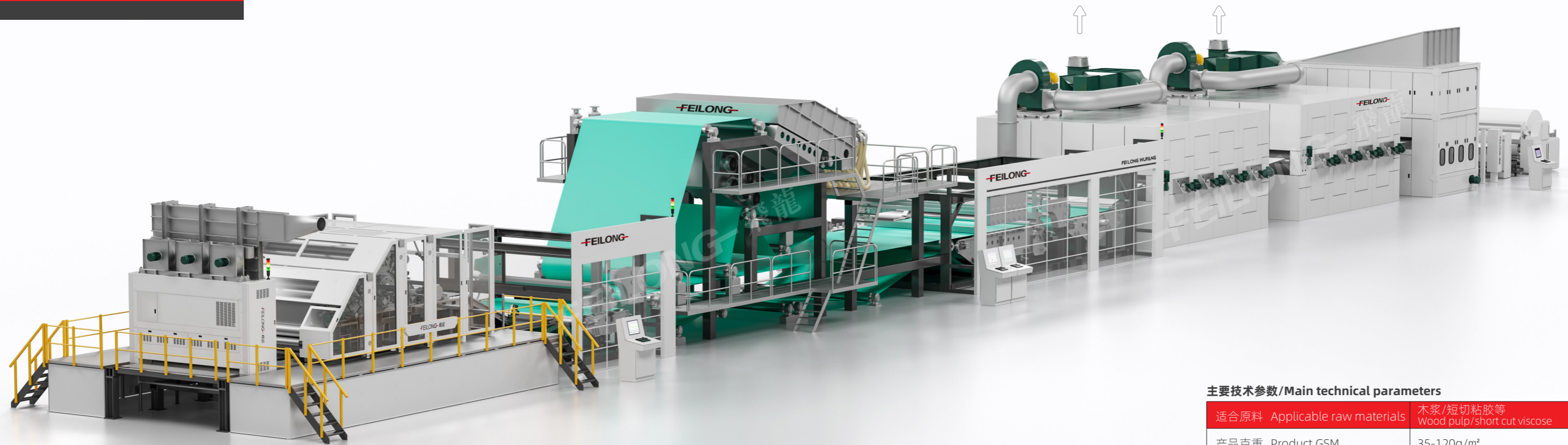

主要技术参数/Main technical parameters

适合原料	Applicable raw materials	木浆/短切粘胶等
		Wood pulp/short cut viscose
产品克重	Product GSM	35-120g/m ²
设备宽度	Machine width	2.5m 3.6m
生产速度	Production speed	120m/min 180m/min 200m/min

图片版权归飞龙所有，侵权必究
 The copyright of the image belongs to Feilong, all rights reserved

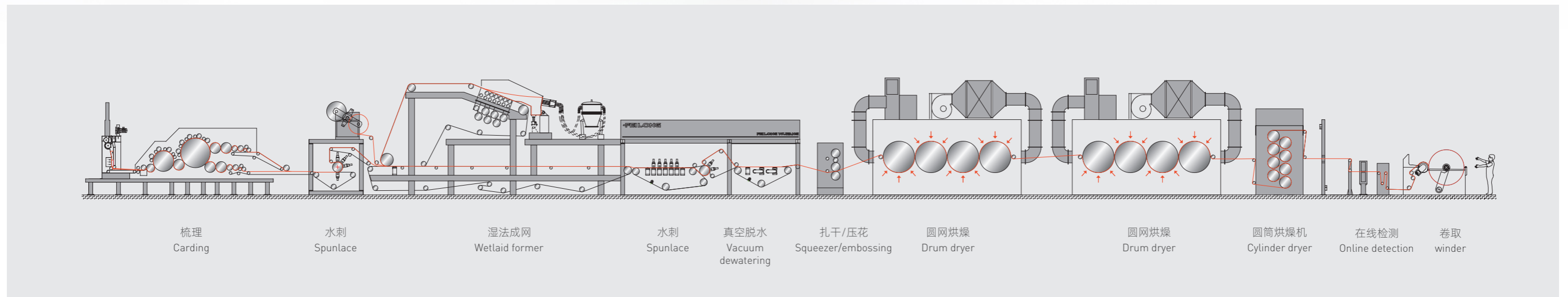

飞龙全系统解决方案
Complete system solution
of Feilong

配置方案

CONFIGURATION PLAN

- 纤维准备
Fiber preparation
- 制浆流程
Pulping process
- 纤维混合
Fiber mixing
- 湿法成网
Wetlaid former
- 纤维复合
Fiber composite
- 水刺系统
Spunlace system
- 脱水干燥
Dewatering/drying system
- 产品检测
Product testing
- 水循环处理
Water circulation system
- 自动化控制
Automation control

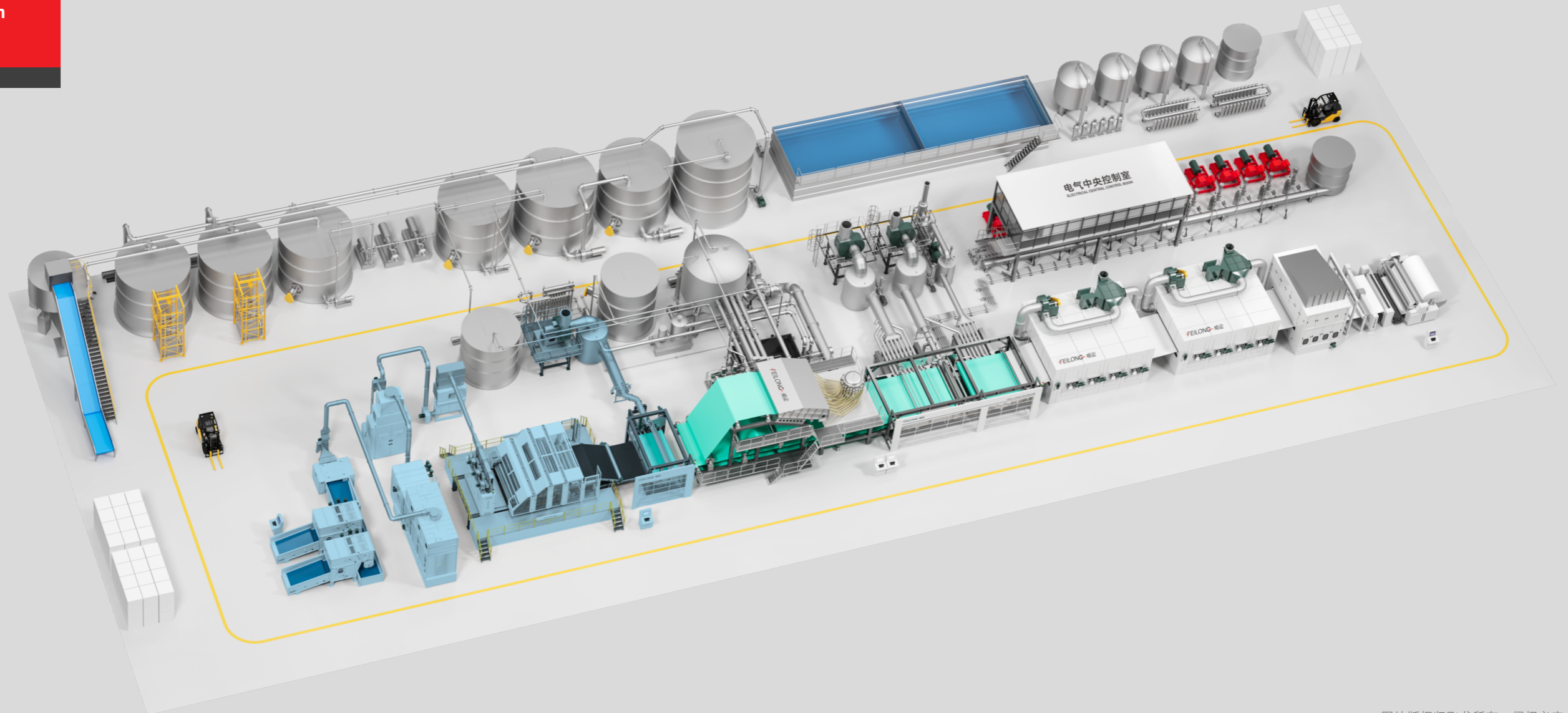

图片版权归飞龙所有，侵权必究
The copyright of the image belongs to Feilong, all rights reserved

我们的服务

OUR SERVICE

01 项目咨询
Project consultation

02 整厂方案
Complete plant solution

03 精良制作
Exquisite production

04 现场调试
On-site commissioning

05 技术培训
Technical training

06 服务保障
Service guarantee

07 开发协助
Development assistance

细化方案
Detailed proposal

湿法成网

WETLAID FORMER

满流式流浆箱，重力脱水及多元分配；
高效白水循环
Full flow headbox, gravity dewatering and multiple distribution
Efficient white water circulation

工艺流程图 Process flow diagram

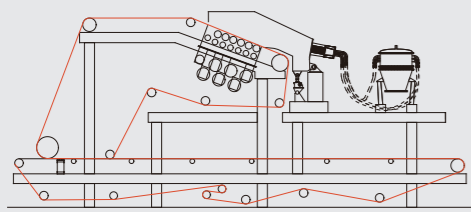

节能脱水/干燥

ENERGY SAVING DEWATERING/DRYING

空抽吸箱采用双头抽吸，布面含水率低及左右均匀；
热风穿透式干燥，高效节能
Double head suction is adopted by the empty suction box, the moisture content of the fabrics surface is low and uniform on both sides;
Hot air-through drying, efficient and energy-saving

工艺流程图 Process flow diagram

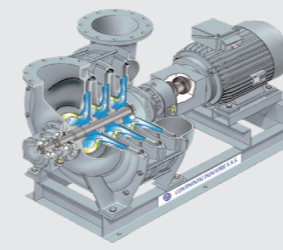

蜂巢式高效穿透
Honeycomb efficient air-through

高压风机
High pressure blower

水刺机系统

SPUNLACE SYSTEM

高效水刺缠结，低木浆流失率，
可带提花功能或压花工艺
Efficient spunlace entanglement, low pulp loss rate, Jacquard function or embossing process available

工艺流程图 Process flow diagram

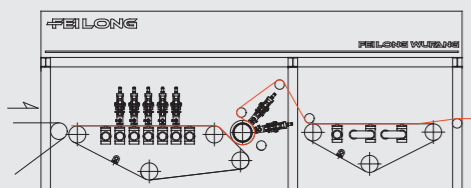

梳理机复合

CARDING MACHINE COMPOSITE

高杂梳理工艺，低牵伸过渡输出
High randomizing carding process, low draft transition output

工艺流程图 Process flow diagram

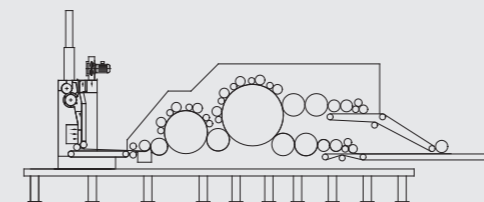

细化方案
Detailed proposal

高压供水
HIGH PRESSURE WATER SUPPLY

水刺专用高压泵辅，专用变频节能
Special high-pressure pump auxiliary for spunlace, special frequency conversion energy-saving



DCS自动控制
DCS AUTOMATIC CONTROL



制浆流程
PULPING PROCESS

医用卫生级别，浆罐及管道抛光，特制法兰密封连接；采用螺旋浆泵输送长纤维浆，减少纤维成团；专有技术浆料混合输送工艺

Medical hygiene level, pulp tank and pipeline polishing, The sealing connection of special flange adopts a screw pump to transport long fiber pulp, Reduction of fiber aggregation; The conveying process of proprietary technology pulp mixing.

工艺流程图 Process flow diagram

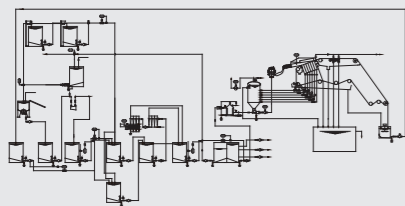

产线介绍

适用原料: 木浆、天丝、粘胶、棉纤维、PLA等
产品用途: 可冲散、民用擦拭、工业擦拭、医用材料等
织物克重: 35-100GSM
产品净宽: ≤3400mm
生产速度: ≤200m/min
产量: 12000吨/年

INTRODUCTION TO THE PRODUCTION LINE

Applicable raw materials: wood pulp, Tencel, viscose, cotton fiber, PLA, etc
Product application: flushable, civil use wipes, industrial wipes, medical materials, etc
Fabric GSM: 35-100GSM
Net width of the product: ≤3400mm
Production speed: ≤200m/min
Production capacity: 12000 tons/year

特色优势

高产能 — ≤200米/分钟速度
低能耗 — 强力真空脱水、热风穿透干燥、专用变频节能
卫生级 — 不锈钢材质、高温杀菌干燥、紫外线杀菌
自动化 — 工艺算法操作自动化

FEATURES AND ADVANTAGES

High production capacity - ≤200 m/min
Low energy consumption - strong vacuum dewatering, hot air through drying, special frequency conversion energy-saving
Hygienic grade - stainless steel material, high-temperature sterilization and drying, UV sterilization
Automation - Operation automation of process algorithms

FEILONG 飛龍®

来源于大自然的享受
A GIFT OF NATURE

 **技术总监**
Technical director +86-13901570515

 **总经理**
General manager +86-18606236230

 **市场部副总**
Vice president of marketing +86-13838055677

 **销售部长**
Sales director +86-18626132010

 **销售经理**
Sales manager +86-15988372939

 **服务部长**
Service director +86-13862340685